



Principal Plant and General Offices
111 North River Road
P.O. Box 207
North Aurora, IL 60542-0207

Toll Free: 1-800-323-5664
Phone: 1-630-897-8489
Fax: 1-630-897-0573
Web Site: www.belson.com

PARK KING

Thank you for buying a BELSON OUTDOORS quality product.

Please read and follow assembly instructions. Refer to appropriate page depending on the table you wish to put together. If the lumber is not provided by Belson, follow drilling instructions on page (2).

INDEX

- 1) FRAME KIT CONTENTS
- 2) LUMBER CONTENTS AND WOOD DRILLING INST.
- 3) WOOD TABLE 6' ASSEMBLY INSTRUCTIONS

PK-WF FRAME KIT CONTENTS:

(2) SUPPORT BRACE

700081

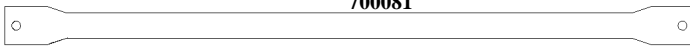

(1) HARDWARE BAG

702304

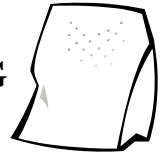

(2) TOP "L" BRACKET

700023

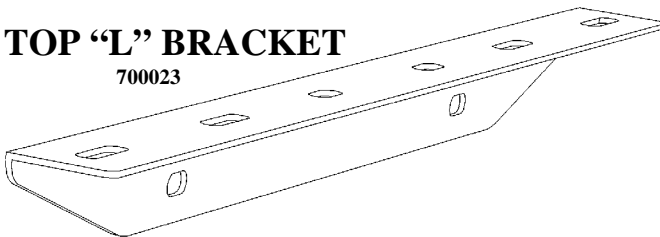

(1) CENTER BRACKET

700043

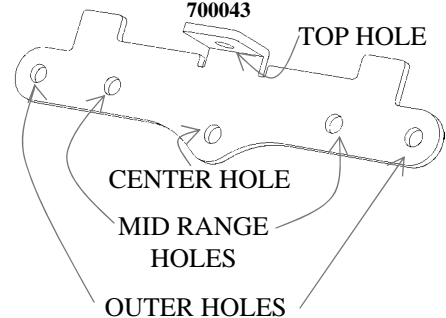

(1) CENTER CHANNEL

700063

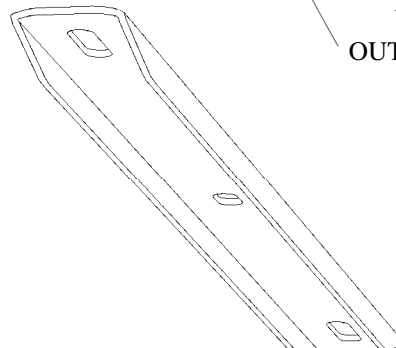

(4) PARK KING "J" LEG

700204

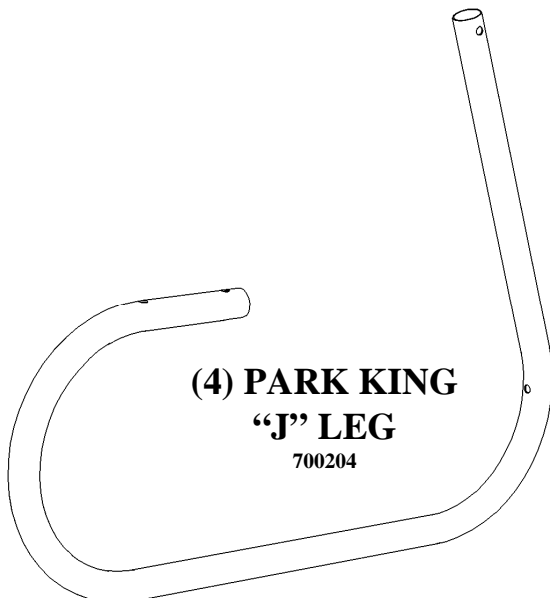

BELSON PRE CUT & PRE DRILLED LUMBER KIT (OPTIONAL)

LUMBER KIT CONTENTS:

○ CENTER (1) ○	○ NO MITERED CORNERS, 5 HOLES ○
○ SIDE (2) ○	○ 2 MITERED CORNERS, 5 HOLES ○
○ SEAT (2) ○	○ 4 MITERED CORNERS, 4 HOLES ○

		NATURAL S. Y. PINE	REDWOOD STAINED	ACQ TREATED
CENTER	6'	700111	700112	700113
SIDE	6'	700131	700132	700133
SEAT	6'	700151	700152	700153

WOOD PICNIC TABLE DRILL PATTERN

TOOLS NEEDED: drill, 3/8" drill bit, pencil and tape measure or ruler.

RECOMMENDED LUMBER: 2" x 10" Nominal (1-1/2" thick by 9-1/4" wide).

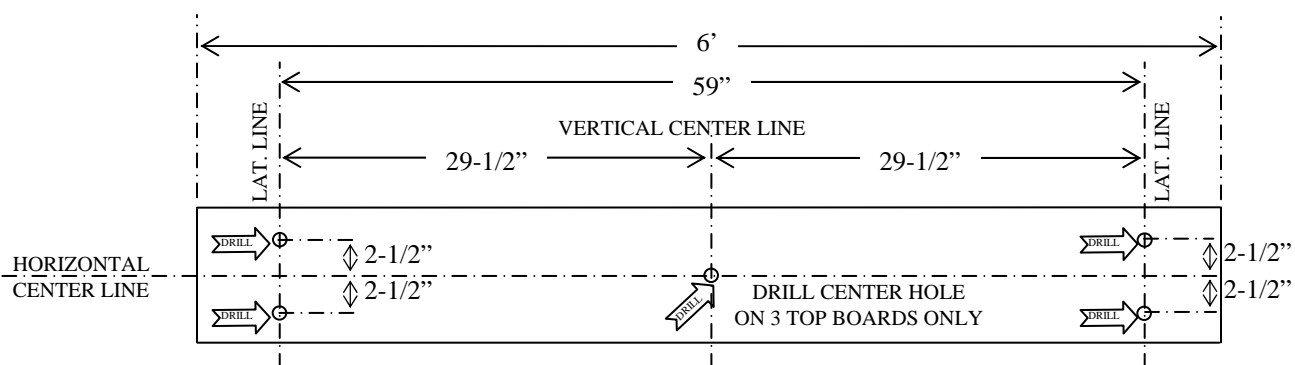

- 1.-Make sure all 5 boards are of consistent length, roughly 6'.
- 2.-Lay all 5 boards on a flat surface that will not damage the wood with the best side down.
- 3.-Draw centered *Vertical* and *Horizontal Lines*, then two *Lateral Lines* 29-1/2" from *Vertical Center Line* on all boards (this will be your reference for hole locations).
- 4.-Drill 3/8" diameter holes in boards per drill pattern and notes indicated above.
- 5.-If desired, cut miters as per top of page lumber kit details and paint or seal before assembly.

6' WOOD PARK KING ASSEMBLY INSTRUCTIONS

TOOLS REQUIRED: 9/16" wrench and hammer.

- 1.- Insert 2-1/4" carriage bolts through 3 Top Boards best face and lay (Side with 2 miters facing out - Center no miters - Side with 2 miters facing out) on a non-abrasive flat surface that will not damage the lumber with the best side facing down.
- 2.- Align Top Boards and space them about 1/8" apart.
- 3.- Place 2 Top "L" Brackets as shown and hand tighten nuts in place.
- 4.- Place the Center Channel with the legs up as shown and hand tighten the 2 outer nuts. Attach Center Bracket's center hole to the center bolt and hand tighten nut.

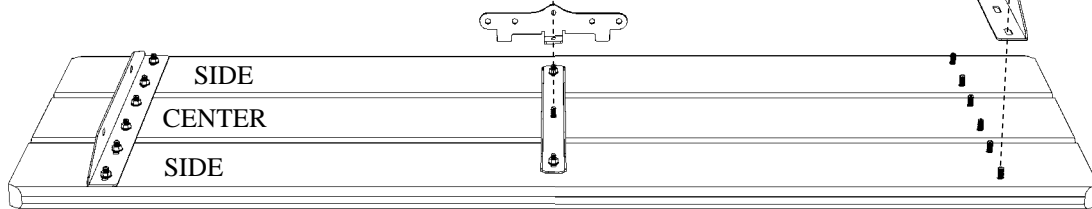

- 5.- Make sure Top Boards are aligned and spaced. Then tighten all 15 nuts.

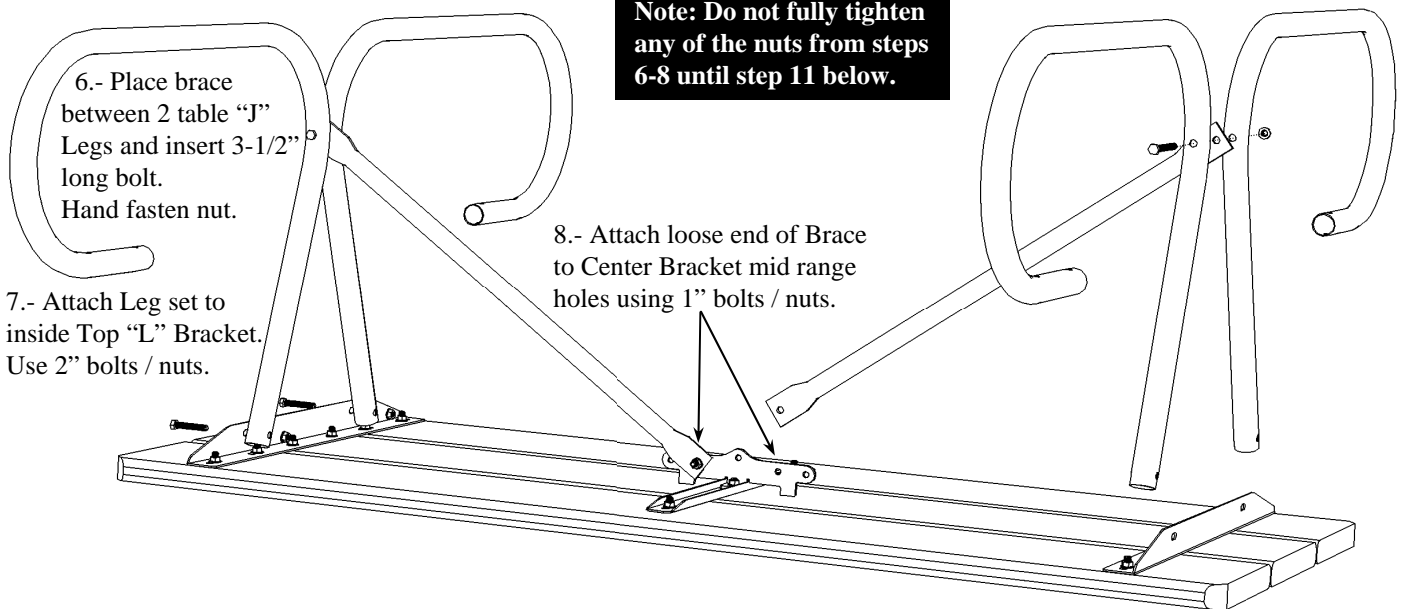

- 9.- Flip the partial table assembly into an upright position.
- 10.- Attach Seats to Frame using 3-1/2" carriage bolts / nuts as shown.

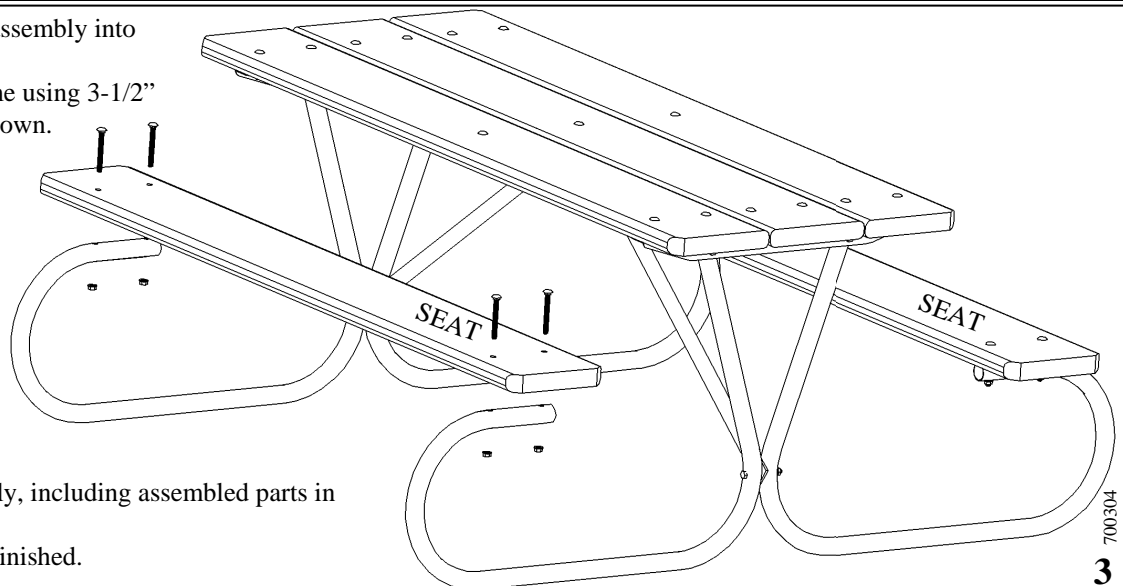

- 11.- Tighten all nuts firmly, including assembled parts in steps 6, 7 and 8.
- 12.- The Picnic Table is finished.